



# R80 USER MANUAL



## Content

<b>Content .....</b>	<b>1</b>
<b>Section 1 Before Start .....</b>	<b>1</b>
1.1 Safety Information .....	1
1.1.1 General Introductions .....	1
1.2 Battery .....	1
1.3 This Product and AC Adapter .....	2
1.4 Regulatory Information .....	3
1.4.1 For EU .....	4
1.4.2 For USA .....	6
<b>Section 2 Getting Started .....</b>	<b>8</b>
2.1 Introduction .....	8
2.2 Unpacking .....	9
2.3 Description of Components .....	10
2.4 Status Indicators .....	14
2.5 Programmable Buttons .....	15
2.6 First-Time Operation .....	15
2.6.1 Installing a Micro SD Card .....	15
2.6.2 Installing SIM card (Optional) .....	16
2.6.3 Connecting to AC Adapter .....	17
2.6.4 Start the tablet .....	18
<b>Section 3 Operating the Device .....</b>	<b>19</b>
3.1 G-Center .....	19
3.1.1 Control Buttons .....	19
3.1.2 System Information .....	19
3.1.3 Shortcuts .....	20
3.1.4 Settings .....	21
3.2 Using the WLAN (Wi-Fi) .....	24
3.3 Using the Optional WWAN (4G LTE) .....	25
3.4 Using the Optional WWAN (RJ45) .....	25
3.5 Using the GPS .....	26
3.6 Using the Bluetooth .....	26
3.7 Using the Optional barcode Reader .....	27



3.8 Using the Optional RS232 Module .....	27
<b>Section 4 Power Management .....</b>	<b>29</b>
4.1 AC Adapter .....	29
4.2 Battery PACK .....	29
4.2.1 Battery Low Signal and Actions .....	30
4.2.2 Replacing the Battery Pack .....	30
4.3 Power Saving Tips .....	32
<b>Section 5 Expanding the Device .....</b>	<b>33</b>
5.1 Installing WWAN Module .....	33
5.2 Replacing the SSD Module .....	34
5.3 Docking Connector Pin Definition .....	34
<b>Section 6 Troubleshooting .....</b>	<b>35</b>



## Section 1 Before Start

### 1.1 Safety Information

#### 1.1.1 General Introductions

To avoid or reduce the risk of electric shock, fire, fault, physical injury, loss of life, and damage to device or property, always observe the following cautions.

#### **DANGER**

Indicates an imminently hazardous situation that, if not avoided, will result in death or serious injury.

#### **WARNING**

Indicates a potentially hazardous situation or an accidental use that, if not avoided, could result in death or serious injury.

#### **CAUTION**

A Caution alert indicates potential damage to hardware and explains how to avoid the potential problem.

#### **NOTE**

Indicates an important notes that is essential to you .

### 1.2 Battery

#### **DANGER**

- If the battery deteriorates, replace it with a new one.
- Do not expose the battery to fire, excessive heat or direct sunlight.
- Do not expose the battery to water or other liquids.
- Do not disassemble, modify, insert foreign objects into the battery or subject it to impact.
- Do not throw the battery or subject it to strong impact such as dropping or applying high voltage.
- Do not short the positive(+) and negative(-) contacts.
- Do not carry the battery around or store it with necklaces, hair clips, etc.
- The battery is for use with this product only. Do not use it together with any other products.



## **WARNING**

- Do not touch leaked electrolyte from the battery.
- Electrolyte may enter the eyes and cause blindness, or may contact skin and cause rashes. Rinse with clean water, do not rub, and seek medical advice.
- Do not place the battery in a microwave oven or pressurized container. Sudden heating or pressurization may damage the battery and cause electrolyte leakage, excessive heating, smoke, burst, or fire.
- If the battery leaks electrolyte or smells, keep the battery away from fire.

## 1.3 This Product and AC Adapter

### **WARNING**

- Do not expose the AC adapter or cable to water or other liquids, as this may cause a short circuit or overheating, which may result in electric shock or fire. If the product gets wet, unplug the AC plug of the AC adapter immediately.
- Do not touch the product, AC adapter or cable during a lightning storm when the product is connected to an AC adapter, as this may result in electric shock.
- Do not insert a metal object into the plug of the AC adapter or cable, as this may result in fire, burns or electric shock.
- Do not insert foreign objects into the product, otherwise it may lead to short circuit or overheating, which in turn may cause electric shock or fire.
- When in prolonged use, do not expose your skin to the product for a long time to avoid possible low temperature burns.
- Do not allow conductive materials to come into contact with the expansion bus connector, as this may cause a short circuit and overheating, which in turn may lead to battery electrolyte leakage, overheating, smoke, burst or fire.
- Do not disassemble the product without authorization, as this may cause a short circuit or overheating, which in turn may cause electric shock or fire.
- Do not place the product in a microwave oven or an electromagnetic cooker as this may cause a short circuit or overheating, which may result in electric shock or fire.
- Keep small parts such as SD card out of the reach of infants and children.
- Please avoid listening at high volume for long time as this may result in damage or loss of hearing. High volume may also make it difficult to hear the surrounding sounds, which may lead to accidents. Use only the specified battery, otherwise it may cause electrolyte leakage, overheating, smoke, burst or fire.
- Do not operate the product while walking, riding a bicycle or driving, etc., as this may result in an accident or a fall.



- When using the product in areas with high concentrations of moisture, steam, dust, oily vapors, etc., make sure to close the port cover to avoid the entry of foreign objects, which may in turn lead to possible electric shock or fire.
- When the product is damaged, water or foreign objects enter the product, the product smokes, the product emits abnormal odor or sound, or the product overheats, stop using the product immediately, unplug the AC plug of the AC adapter, remove the battery and contact technical service.
- When exposed to certain light patterns or flashing lights for long time, very few people may experience seizures or blackouts. If you experience any discomfort while staring at the flashing lights on the screen, stop using the product immediately and consult your doctor.
- Clean the AC plug of the AC adapter regularly. If dust or other debris stores up on the plug, moisture, etc. may cause insulation defects, which in turn may lead to fire.
- Do not damage or modify the cable. Do not place it near hot tools, twist, pull hard, or deform the cable. Continued use of a damaged AC adaptor or cable may result in fire or electric shock.
- Plug the AC plug of the AC adapter completely in, otherwise a fire may result from overheating or electric shock.
- Do not pull out or insert the AC plug of the AC adapter if your hands are wet. It may result in electric shock. Do not use a damaged AC plug or loose AC outlet.
- Do not use this product near electronic equipment used for high-precision control or weak signals, such as: hearing aids, implantable pacemakers and implantable cardioverter-defibrillators, other medical devices, fire alarms, automatic doors, and other automatic control devices. RF signals generated by this product may interfere with such electronic equipment and cause accidents due to malfunction.
- In aircraft, connect the AC adapter/charger only to an AC outlet specifically approved for such use.
- Do not connect the AC adapter to a power source other than a standard household AC outlet, as this may cause a fire due to overheating. Connecting to a DC/AC converter(inverter) may damage the AC adapter.

## 1.4 Regulatory Information

### This Product and Your Health

The radio frequency electromagnetic energy of this product functions within radio frequency safety standards. We believe this product is safe for use. In certain situations or environments, the use of this product may be restricted by the responsible representatives of the building or organization. These situations may include, for example, the use of this product in aircraft, or in medical facilities where equipment in using is sensitive to external RF energy, or in any other



environment where the risk of interference with other equipment or services is considered or determined to be harmful. If you are unsure of the policies that apply to the use of wireless devices in a particular organization or environment, we encourage you to request authorization to use the product before turning on the device.

## **Information to the User**

We are not responsible for any radio or television interference caused by unauthorized changing to this product, and for correcting interference caused by such unauthorized changing. We and our authorized distribution partners or resellers are not responsible for damages or violations of government regulations that may result from failure to comply with these standards.

## **Potentially Explosive Atmosphere**

Sparks in areas with potentially explosive atmospheres may cause an explosion or fire, to avoid personal injury or even death, in chemical plants, fuel or chemical transfer or storage facilities, below decks on ships, vehicles using oil or natural gas, refueling areas, or the atmosphere areas containing particles such as grain, dust, or metal powder, and any other area where it is generally recommended that you turn off the engine of your vehicle, turn off the product, and obey all signs and instructions.

## **Driving**

Do not operate the product while driving, safe driving is your primary responsibility. Get off the road and pull over before making or answering a phone call. Do not place or install the product in the area above the air bag or in the deployment area. If the air bag inflates, serious personal injury and/or damage could result. Check the laws and regulations in the area where you drive, and always obey them. Regularly check that the product is securely mounted and functioning properly in your vehicle. Radio frequency signals may affect improperly installed or inadequately shielded electronic systems in motor vehicles.

## **Emergency Communications**

Network connections can be disrupted by a variety of factors, such as low battery levels, weak radio signals, and problems with service networks. Do not rely solely on the product for essential or emergency communications.

## **Antenna**

Do not replace the antenna without authorization. Unauthorized antennas, modifications, or attachments may cause damage to the product and may even violate regulations that are designed to protect consumers and ensure safety. The product performance may be affected when the device is turned on, if the antenna area is touched or covered.

### **1.4.1 For EU**

After the laboratory measurements the Max. SAR values for this device is: Body: 0.497 W/kg.

# SECTION 1 BEFORE START



- The device complies with RF specifications when the device used at 0cm from your body.
- The product shall only be connected to a USB interface of version USB3.1.



- Use carefully with the earphone maybe possible excessive sound pressure from earphones and headphones can cause hearing loss.
- **CAUTION: RISK OF EXPLOSION IF BATTERY IS REPLACED BY AN INCORRECT TYPE. DISPOSE OF USED BATTERIES ACCORDING TO THE INSTRUCTIONS.**
- Adapter shall be installed near the equipment and shall be easily accessible.
- The plug considered as disconnect device of adapter.
- EUT Operating temperature range: -10-55°C.
- This product can be used across EU member states.
- Declaration of Conformity

Hereby, Shanghai UniOne Science & Technology Co., Ltd. declares that the radio equipment type GTW5081 is in compliance with Directive 2014/53/EU. The full text of the EU declaration of conformity is available at the following internet address: [www.rugstorm.com/download](http://www.rugstorm.com/download).



- Operations in the 5.15-5.35 GHz band are restricted to indoor usage only.
- This Frequency the following Member States or the geographical area within a Member State where restrictions on putting into service or requirements for authorization of use exist.

BE	BG	CZ	DK	DE
EE	IE	EL	ES	FR
HR	IT	CY	LV	LT
LU	HU	MT	NL	AT
PL	PT	RO	SI	SK
FI	SE	UK(NI)		

Frequency Range And Maximum Power :

Wi-Fi 2412-2472 MHz: 18.47 dBm,

Wi-Fi 5180-5700 MHz: 21.28 dBm,

Wi-Fi 5745-5825 MHz: 13.76 dBm,





Bluetooth: 9.5dBm/BLE: 5.5 dBm,

BT+EDR: 2402-2480 MHz: 6.52dBm,

BT LE: 2402-2480 MHz: 8.38dBm.

## 1.4.2 For USA

This equipment has been tested and found to comply with the limits for a Class B digital device, pursuant to part 15 of the FCC Rules. These limits are designed to provide reasonable protection against harmful interference in a residential installation. This equipment generates uses and can radiate radio frequency energy and, if not installed and used in accordance with the instructions, may cause harmful interference to radio communications. However, there is no guarantee that interference will not occur in a particular installation. If this equipment does cause harmful interference to radio or television reception, which can be determined by turning the equipment off and on, the user is encouraged to try to correct the interference by one or more of the following measures:

- Reorient or relocate the receiving antenna.
- Increase the separation between the equipment and receiver.
- Connect the equipment into an outlet on a circuit different from that to which the receiver is connected.
- Consult the dealer or an experienced radio/TV technician for help.

### **CAUTION:**

**ANY CHANGES OR MODIFICATIONS TO THIS DEVICE NOT EXPLICITLY APPROVED BY MANUFACTURE COULD VOID YOUR AUTHORITY TO OPERATE THIS EQUIPMENT.**



- This device complies with part 15 of the FCC Rules. Operation is subject to the following two conditions:
  - (1) This device may not cause harmful interference, and
  - (2) This device must accept any interference received, including interference that may cause undesired operation.
- RF Exposure Information and Statement:

The SAR limit of USA (FCC) is 1.6 W/kg averaged over one gram of tissue.

Device types: GTW5081 (FCC ID: 2A96I-GTW5081) has also been tested against this SAR limit. The highest SAR value reported under this standard during product certification for use on the body is 1.584 W/kg. This device was tested for typical body-worn operations with the back of the handset kept 0mm from the body. To maintain compliance with FCC RF exposure requirements, use accessories that maintain a 0mm separation distance between the user's body and the back



of the handset. The use of belt clips, holsters and similar accessories should not contain metallic components in its assembly. The use of accessories that do not satisfy these requirements may not comply with FCC RF exposure requirements, and should be avoided.

This device was tested for typical body-worn operations. To comply with RF exposure requirements, a minimum separation distance of 10mm must be maintained between the user's body and the handset, including the antenna. Third-party belt-clips, holsters, and similar accessories used by this device should not contain any metallic components. Body-worn accessories that do not meet these requirements may not comply with RF exposure requirements and should be avoided. Use only the supplied or an approved antenna.

Operations in the 5.15-5.35 GHz band are restricted to indoor usage only.



## Section 2 Getting Started

### 2.1 Introduction





R80 is a rugged tablet that boasts an 8" 1920x1200 high resolution IPS LCD panel. This ensures exceptional image quality, visibility, and anti-glare properties, making it suitable for both indoor and outdoor working environments. With the Intel® Pentium® N6415 processor, 8GB LPDDR4X memory, and a 128GB SSD (upgradeable to 512GB SSD), R80 guarantees stable performance for multitasking. Integrated Wi-Fi 6 technology and optional 4G cellular network, R80 provides out-standing wireless communication capability. User-replaceable expansion port design of R80 offers a perfect suitable solution for various interface requirements from different industrial applications.

#### Key Features

- Windows® 10 IoT Enterprise, Intel® Pentium® N6415
- 8" 1920 x 1200 resolution
- 8GB LPDDR4X, 128GB SSD(up to 512 GB SSD)
- Support wet & glove-friendly touch
- IP65 protection
- Replaceable battery
- Expansion ports of RJ45/USB2.0/RS232
- Wi-Fi 6, BTv5.1, optional 4G LTE
- Built-in GPS
- Complete Accessory Package to facilitate your work



## 2.2 Unpacking

Tablet	Power Adapter
	
Stylus Pen	Power Cord
	
QSG	
	

**NOTE:**

The image is for reference only, and the actual product may have slight variations.  
The adapter accompanying the device may vary depending on the country of export.



## 2.3 Description of Components

### Front Components

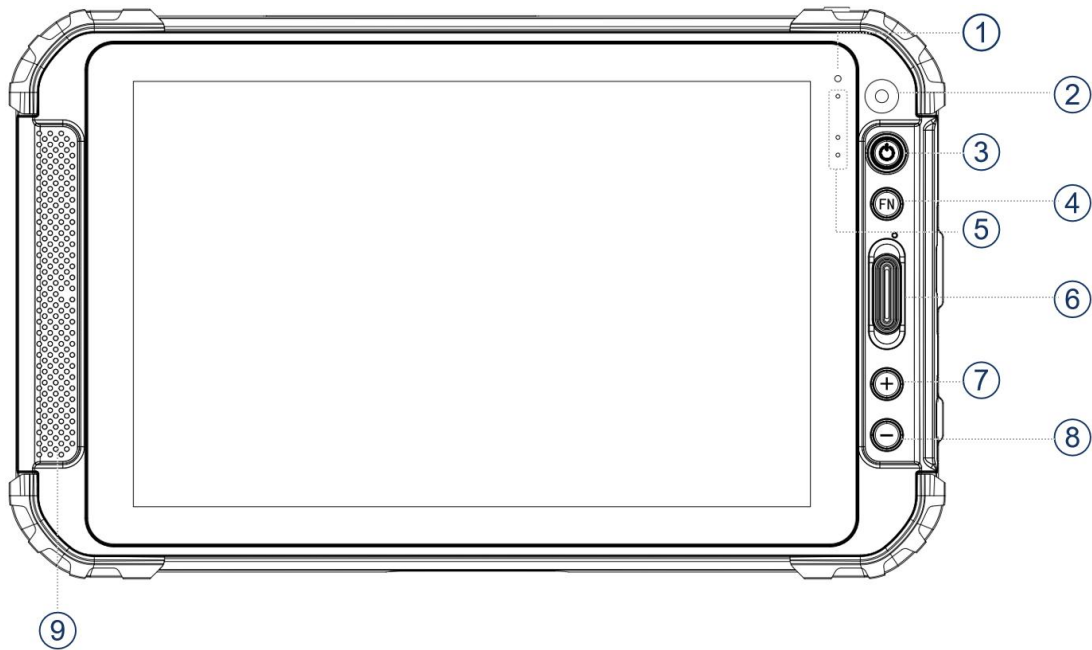

NO	Item	Description
①	Light Sensor	Senses the ambient light for automatic adjustments of the display backlight.
②	Front Camera	Allows you to use the camera function. When the camera is in use, the indicator beside it lights up.
③	Power	Turns the power on or off. (The default "off" state is ("Sleep mode.")
④	Fn Button	Default: Lock the rotation of the screen. When the screen rotation lock is enabled, the screen will remain fixed in either portrait or landscape mode, regardless of how you hold or tilt the device. function key can be configured by G-center.
⑤	Indicators	Show the current status of the Tablet: Power, Battery, Front Camera.
⑥	Home Button	Default: return to the desktop. function key can be configured by G-center.
⑦	Plus Button	Default: increase the volume. function key can be configured by G-center.



⑧	Minus Button	Default: decrease the volume. function key can be configured by G-center.
⑨	Speaker	Emit the sound.

## Rear Components

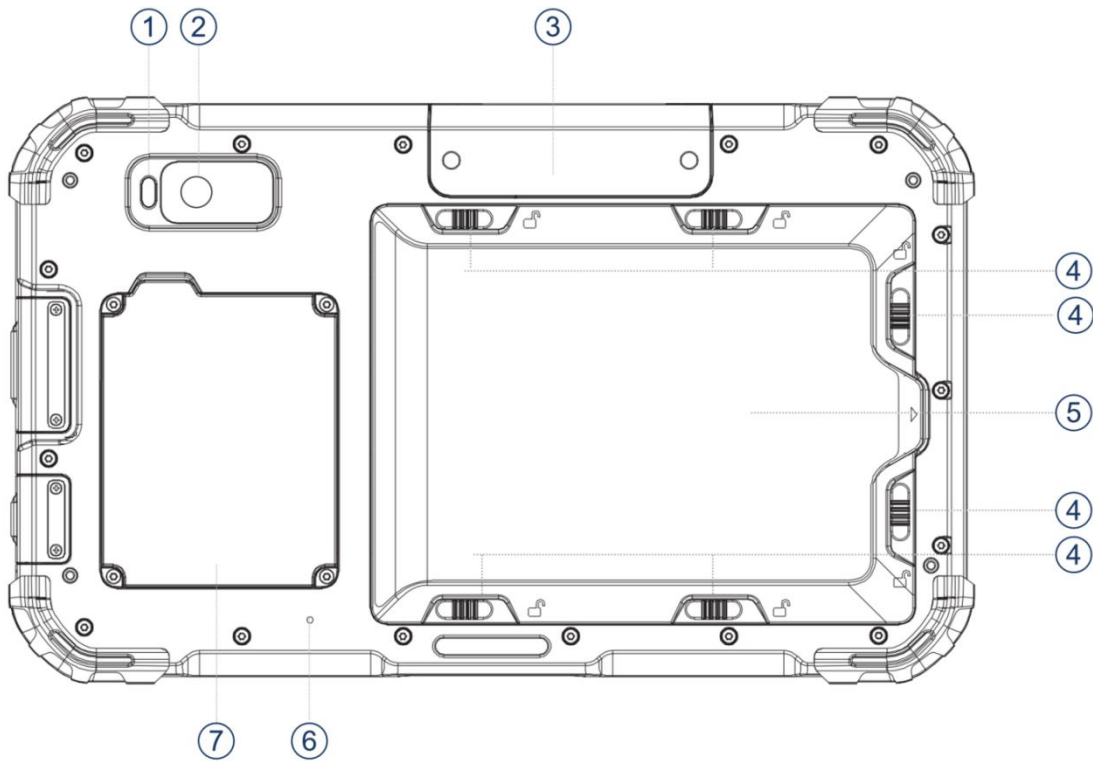

NO	Item	Description
①	Flashlight	Provides extra light while taking pictures.
②	Camera	Allows you to use the camera function.
③	Expansion Slot	Install some function accessories: RJ45, USB, RS232, Barcode Scanner.
④	Battery Cover Latch	Latch to lock the battery cover in place once battery is inserted properly.
⑤	Battery Compartment	There is one battery packs inside.
		The SD card slot is inside.
⑥	Waterproof Breathable Vent	Balance the internal and external air pressure and prevent water and dust from entering the tablet.
⑦	Service Window	Provide access to 4G LTE Module and SSD Module.



## Right-Side Components

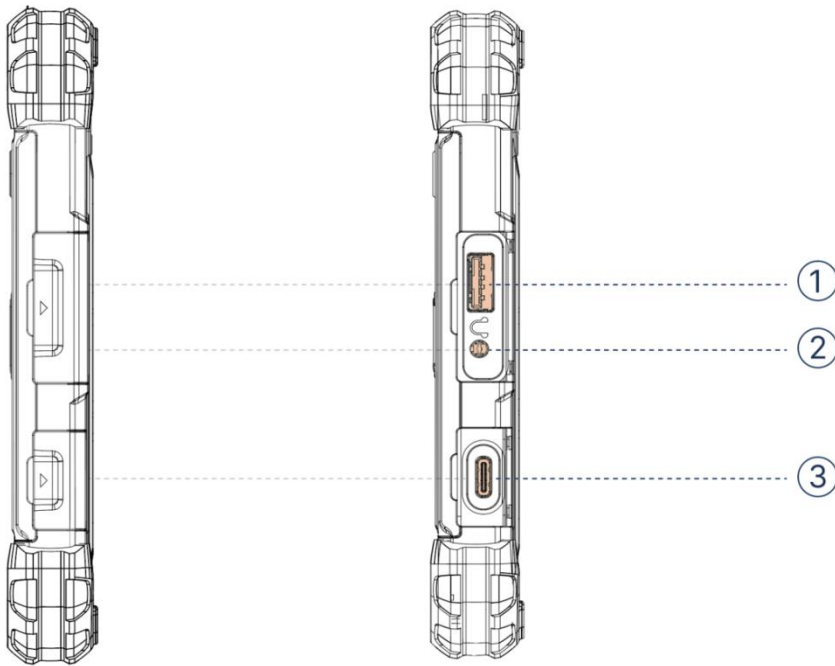

NO	Item	Description
①	USB3.1 Type-A	High speed USB port connects to USB devices.
②	3.5mm Audio Jack	Connect to a headset or a headphone. Microphone is only supported with 3.5mm 4-pin headset.
③	USB3.1 Type-C	USB 3.1 port connects to USB devices.



## Top Components

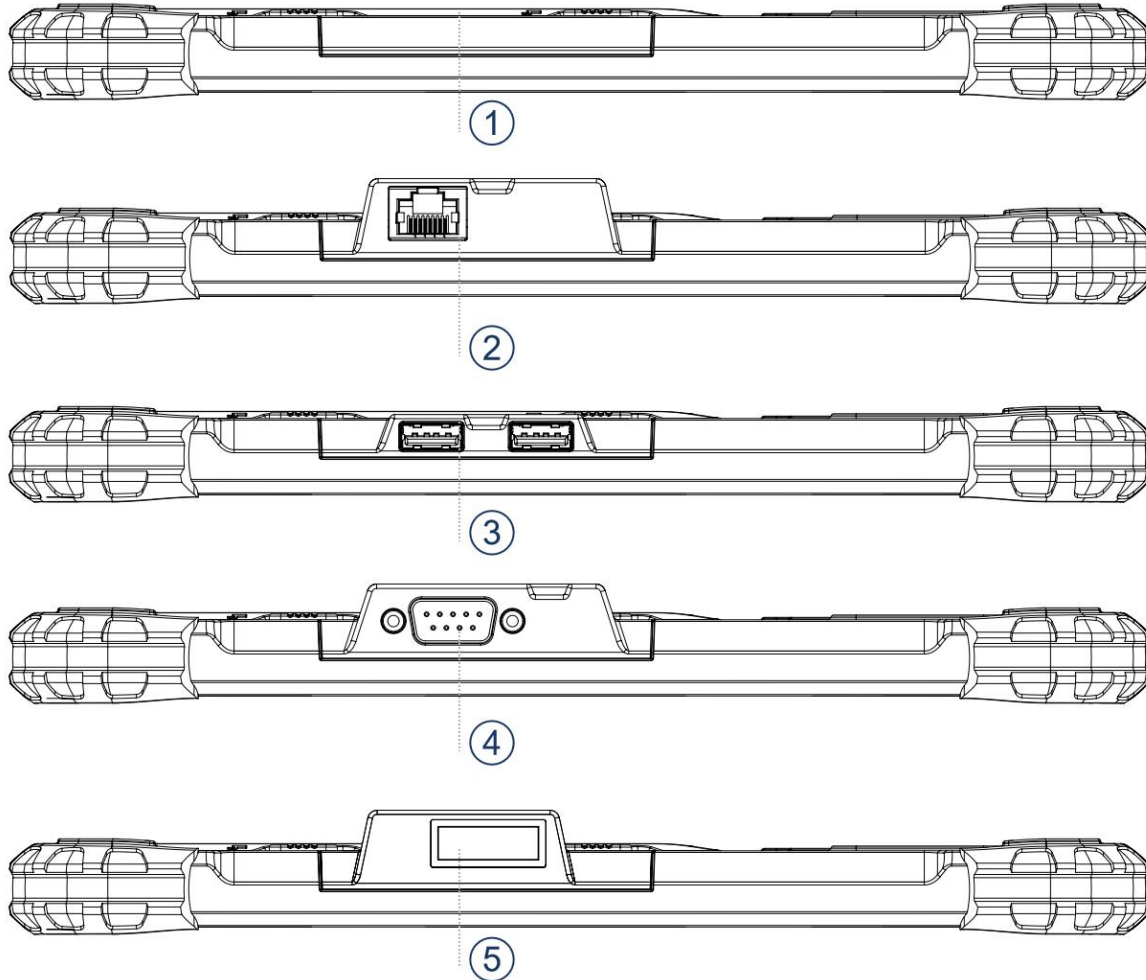

NO	Item	Description
①	Expansion slot	Install below accessories: RJ45, USB, RS232, Barcode Scanner.
②	RJ45	Connects the LAN cable.
③	USB	Connects two USB2.0 devices.
④	RS232	Connects a serial port.
⑤	Barcode Scanner	Scan and read 1D/2D barcode.





## Bottom Components

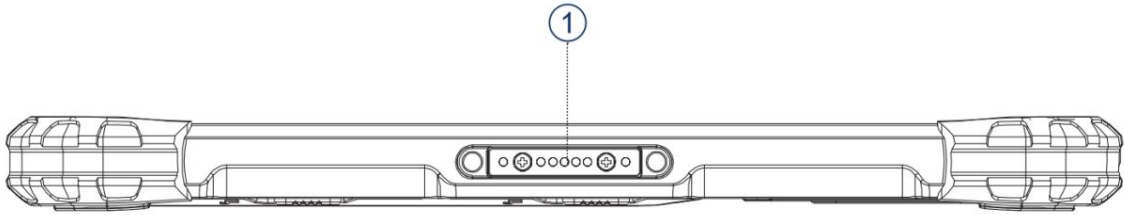

NO	Item	Description
①	Docking Connector	Port to docking solutions such as office dock, vehicle dock to provide power and transmit the signal.





## 2.4 Status Indicators

LED	LED Status	Description
Power	Green	The device is powered on.
	Flashing Green	The device is in sleep mode.
	Off	The device is shut down or in hibernation mode.
Battery	Red	Battery is charging.
	Green	Battery is fully charged.
	Flashing Green	The battery's built-in high temperature protection mechanism is activated.
	Flashing Red	In DC mode, battery capacity is lower than 10%. In AC mode, the battery's built-in high temperature protection mechanism is activated. Turn off the device ASAP to cool it down.
Front Camera	White	Front Camera is on.
	Off	Front Camera is off.



## 2.5 Programmable Buttons

R80 has five buttons and the default function as below, except for **Power**, the **Home**, **Fn**, **+**, and **-** are programmable. You can change the button function in **Section 3.1 U-center introduction**.

Button Name	Keystrokes
Power 	Press power button to turn on the tablet. Long press power button to hard turn off the tablet.
Fn 	Default: Screen rotation lock, when the tablet has no G-center.
Home 	Default: Return to the desktop
+ 	Default: Volume up
- 	Default: Volume down

## 2.6 First-Time Operation

To start to operate the tablet, you can follow below steps:

1. Read Quick Start Guide firstly.
2. Install SD card or SIM card if necessary.
3. Install the battery.
4. Charge your tablet.
5. Start the tablet.

### 2.6.1 Installing a Micro SD Card

1. Remove the battery, following in **Section 4.2.2 Replacing the Battery Pack**.
2. Insert the micro SD card into the slot, contact facing down.
3. Replace the battery, following in **Section 4.2.2 Replacing the Battery Pack**.

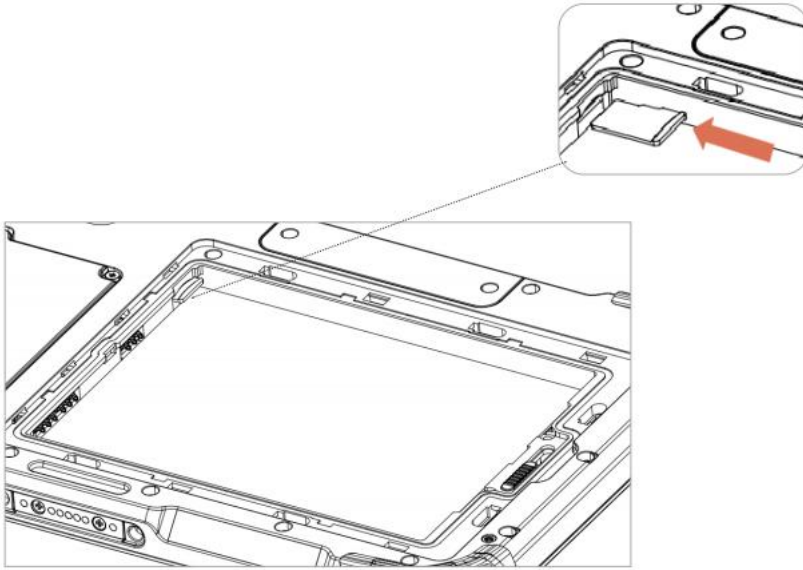

## 2.6.2 Installing SIM card (Optional)

WWAN module is an optional feature, and it is available and tailored for specific models. Check your order specification before start it.

### CAUTION:

Before installing WWAN module, turn off the tablet, back facing up.

1. Use T6 screwdriver to remove four screws and the compartment cover.
2. Push the SIM card metal cover to the right side, and lift it gently.

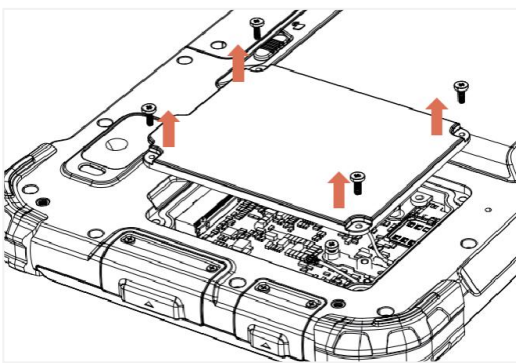

Compartment Cover Screw: M2x5, 4pcs.

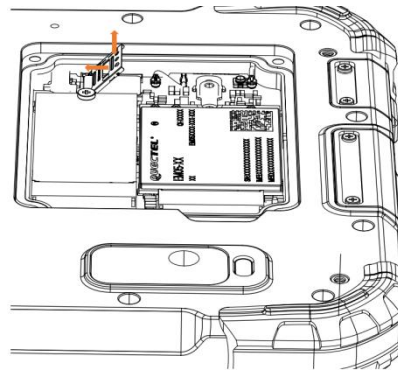

3. Put the SIM card properly, contact facing down. Then lay down the SIM card metal cover and pull it back.

4. Close the compartment cover and fasten four screws.

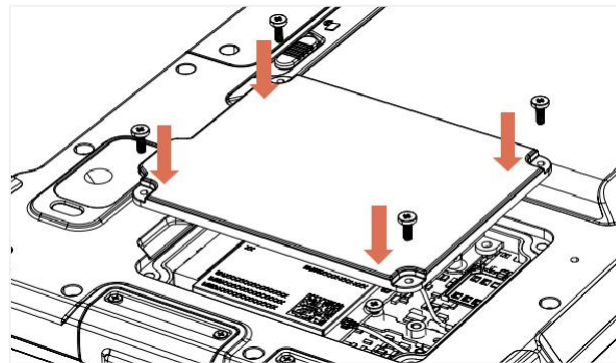
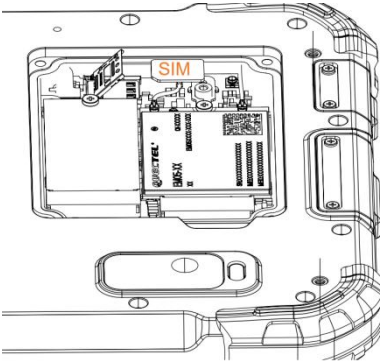

## 2.6.3 Connecting to AC Adapter

### CAUTION:

Please only use the AC adapter that comes with your Tablet Computer. Using any other AC adapters may result in damage to both the Tablet Computer and the Battery.

### NOTE:

The device is powered by both an AC adapter and a battery. Upon receiving the device for the first time, please use the AC adapter to charge it as it may be in power saving mode.

1. Open the lower I/O protect cover on the right by pulling out the latch.
2. plug the power cord into the power connector of the tablet.
3. Plug the power cord to the AC adapter.
4. Plug the adapter to the electrical outlet.

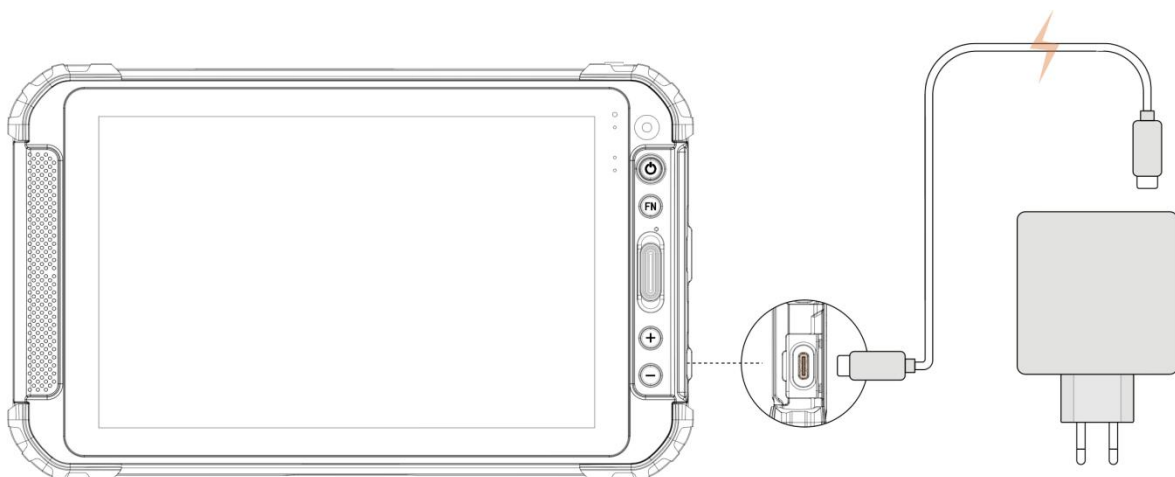

The electrical outlet is supplying power to the AC adapter, which in turn powers your Tablet PC. Now, you are ready to turn on the Tablet PC.

There are four status of battery indicator, please check **Section 2.4 Status Indicators** for detail.





## 2.6.4 Start the tablet

### Turn on

Press the power button  for 1 second until the yellow power indicator light up.

### Turn off

Before you turn off your tablet, make sure you have closed any programs that are open on the Desktop. You can select one of three mode to stop the system according to your preference.

Modes	How to do...
Power Off	Tap  → Power → Shut down.
Sleep Mode	Press the power button.* -or Tap  → Power → Sleep.
Hibernation Mode	By default, this option is not shown in the Start menu. If you want to use the feature, set up accordingly in Control Panel → shutdown setting.

\* "Sleep" is the default setting of the power button. You may change what the power button does in Windows settings.





## Section 3 Operating the Device

### 3.1 G-Center

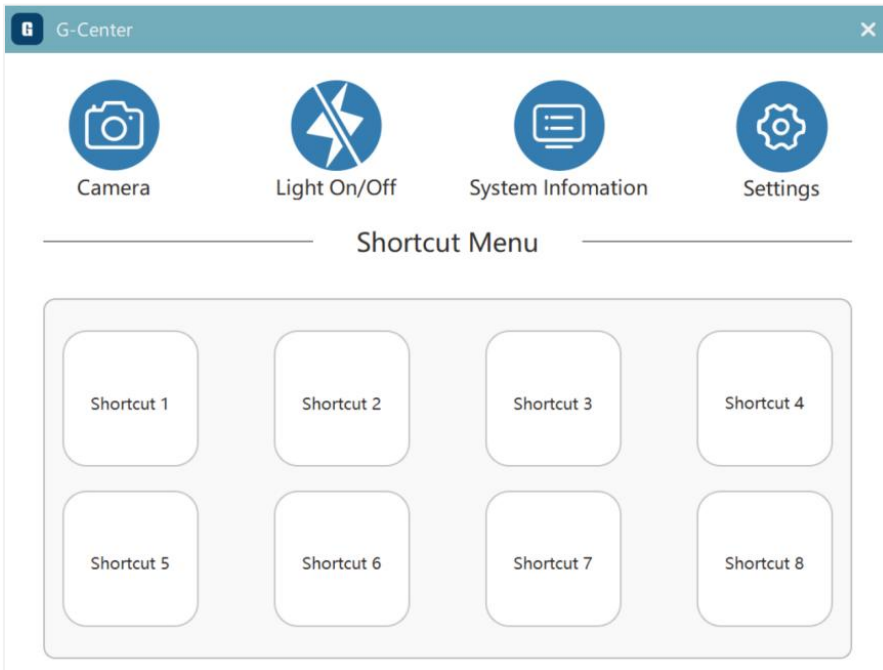
G-Center provides the ability to view, manage, and configure various system functions and features. The home menu of G-Center consists of four categories. Simply select a category name to access its contents.



#### 3.1.1 Control Buttons

Button	Name	Function
	Camera	start or use the Camera.
	Light On/Off	Turn on or turn off the flashlight.

#### 3.1.2 System Information

The **System** menu presents essential system information but does not contain any configuration options.



## 3.1.3 Shortcuts

The **shortcuts** offers a user-friendly interface that allows you to easily activate or operate specific functions on your Tablet PC with a simple touch of the screen.

You can manage the ten shortcuts in **3.1.3 Settings** → **Shortcut Settings**.





## 3.1.4 Settings

The **Settings** provides you the interface to check and manage the G-Center function, including Programmable Buttons, Shortcut, Touch Mode and so on.

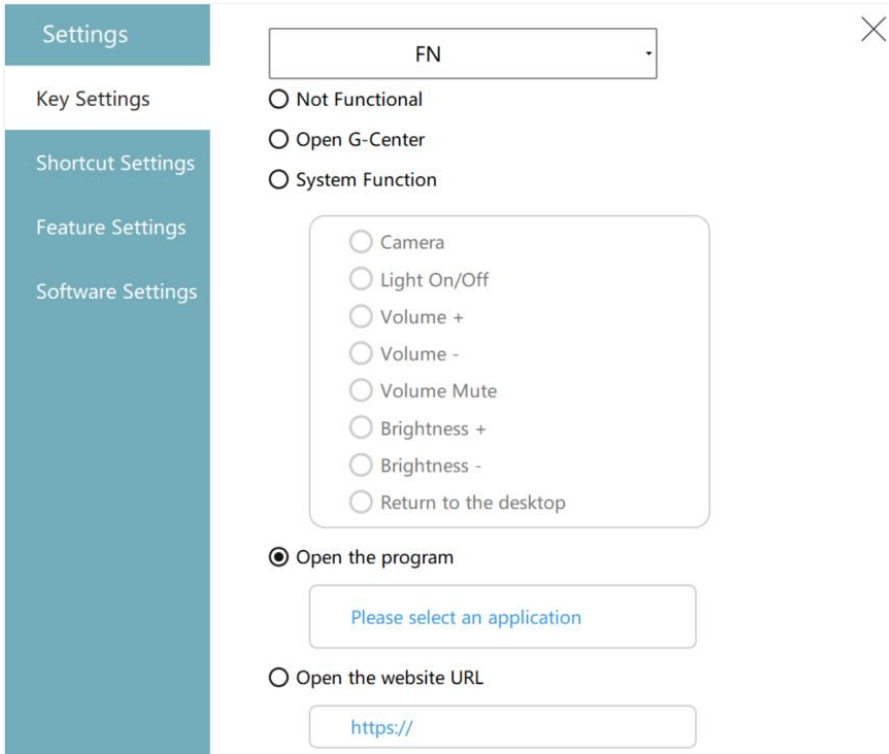

### Key Settings

The **Key Settings** allows you to configure the programmable buttons function. You can confirm the programmable buttons that can be configured in related section of the user manual. The screenshots in this section are just an example and may vary depending on your tablet model.

Here are action list you can configure for your programmable buttons.

Action	Function
<b>Not Functional</b>	Do nothing.
<b>Open G-Center</b>	Open G-Center.
<b>System Function</b>	Start one function in the list.
<b>Open the program</b>	Start the specified program.
<b>Open the website URL</b>	Open the specified URL.





You can configuring programmable buttons following below steps.

1. Tap the down arrow to open the drop-down list. Then choose the programmable button you intend to configure.

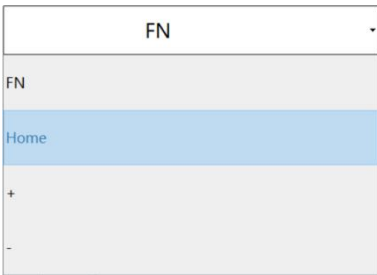

2. Tap the action you want. You can check the upper action list to know what each action means.
3. If you choose “**System Function**”, select the action you want.

System Function

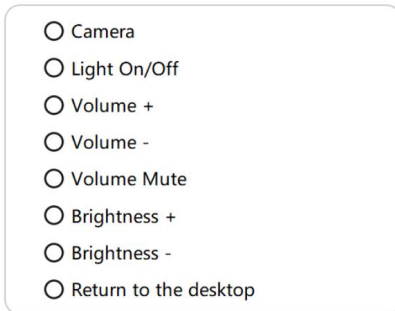

4. If you choose “**Open the program**”, tap the box, then browse the dialog box and select the intended program. Then click **Open** to complete.

Open the program

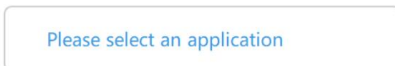

5. If you choose “**Open the website URL**”, tap the box, type in the desired website and click **OK** to complete.

Open the website URL



## Shortcut Settings

You can configuring Shortcuts following below steps.

1. Tap the down arrow to open the drop-down list. Then choose the shortcut you intend to configure.
2. Tap the action you want. You can check the upper action table to know what each action means.



3. If you choose “**System Function**”, then select the action you want.

System Function

- Camera
- Light On/Off
- Volume +
- Volume -
- Volume Mute
- Brightness +
- Brightness -
- Return to the desktop

4. If you choose “**Open the program**”, tap the box, then browse the dialog box and select the intended program. Then click **Open** to complete.

Open the program

Please select an application

5. If you choose “**Open the website URL**”, tap the box, type in the desired website and click **OK** to complete.

Open the website URL

https://

## Feature Settings

The **Feature Settings** allow you to manage **Touch Mode** and **Battery Protection Mode**.

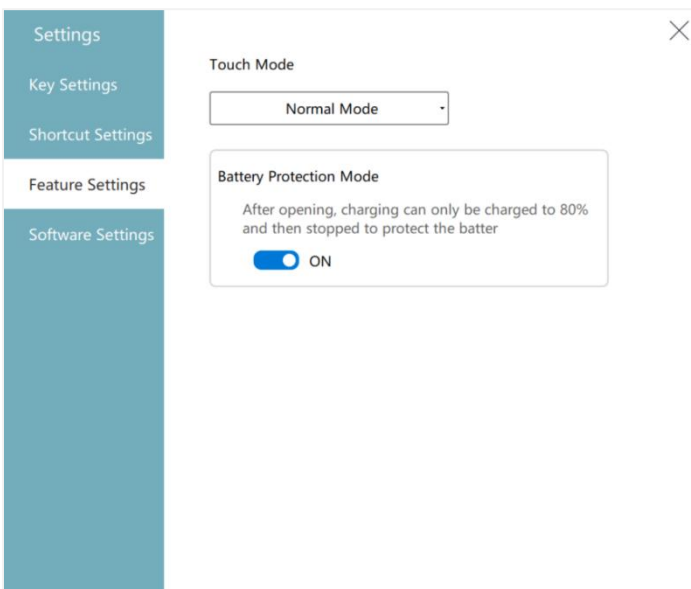

You can switch the **Touch Mode** between **Normal Mode** and **Glove Mode** by tap the down arrow to open the drop-down list. Then choose the mode you intend to configure.

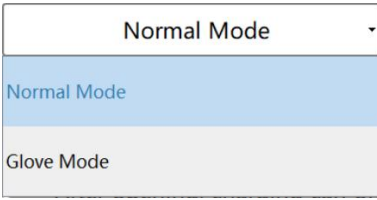

## Software Settings

The **Software Settings** allows you to switch the language of G-Center between English and Chinese and reset G-Center to the default configuration.

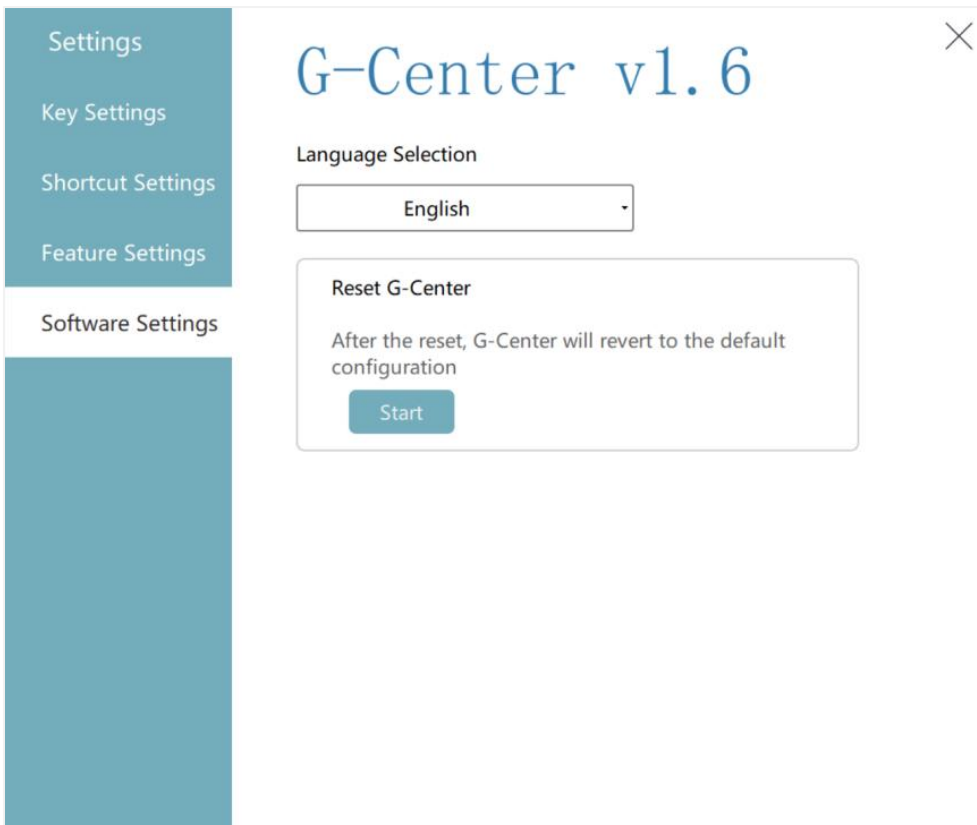

## 3.2 Using the WLAN (Wi-Fi)

R80 WLAN (Wireless Local Area Network) module supports IEEE 802.11.ax, compatible with 802.11a/b/g/n/ac.

### To turn on the WLAN radio:

Tap  → **Settings** → **Network & Internet** → **Wi-Fi**. Slide the Wi-Fi switch to the **On** position.

### To turn off the WLAN radio:

You can turn off the WLAN radio the same way you turn it on.

If you want to quickly turn off all wireless radio, simply switch on Airplane mode.

Tap  → **Settings** → **Network & Internet** → **Airplane Mode**. Tap the switch to the on status to



enable airplane mode.

## Connecting to a WLAN Network:

1. Ensure the WLAN function is enabled (as described above).
2. Tap the network icon  in the lower right of the task bar.
3. Select a network from the list of available wireless networks, and then tap **Connect**.
4. Some networks require a network security key or passphrase. To connect to one of those networks, ask your network administrator or Internet service provider (ISP) for the security key or passphrase.

For further guidance on configuring a wireless network connection, please consult the Windows online help.

## 3.3 Using the Optional WWAN (4G LTE)

The Tablet Computer is compatible with 3G/LTE modules and can accommodate a Micro-SIM card. (The 4G LTE feature is optional). Prior to utilizing this feature, please refer to the related sections to properly install the 4G LTE module and SIM-card.

NOTE: For guidance on how to install the SIM card, please consult Section 2, specifically the section titled "Installing SIM card (Optional)".

### To turn on the WWAN radio:

Tap  → **Settings** → **Network & Internet** → **Cellular**. Slide the **Cellular** switch to the **On** position.

### To turn off the WWAN radio:

You can turn off the WWAN radio the same way you turn it on.

If you want to quickly turn off all wireless radio, simply switch on Airplane mode. Tap  → **Settings** → **Network & Internet** → **Airplane mode**. Tap the switch to the **on** status to enable airplane mode.

### Setting up a WWAN Connection

Tap  → **Settings** → **Network & Internet** → **Cellular**. (For detailed information on cellular settings in Windows 10, see Microsoft Support website.)

## 3.4 Using the Optional WWAN (RJ45)

The LAN Port (RJ45) is an optional feature and may not be available on your device. Refer to your order specifications for additional information.

To establish a connection between the network cable and the LAN module, attach one end of the LAN cable to the RJ45 connector on the Tablet PC and the other end to the network hub.

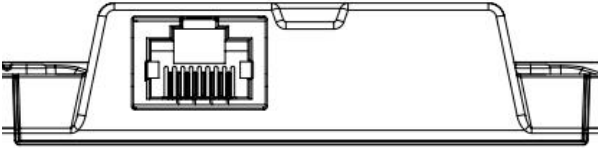

## 3.5 Using the GPS

GPS (Global Positioning System) technology enables precise determination of the computer's geographic location, providing data that can be used for navigation and various other purposes.

NOTE:

You need to install third-party software to take full advantage of the GPS feature.

Do not block the antenna area.

### To turn on the GPS radio:

Tap  → **Settings** → **Network & Internet** → **Airplane mode**. Tap the **GPS/GNSS** switch to the **On** status.

### To turn off the GPS radio:

You can turn off the GPS radio the same way you turn it on. If you want to quickly turn off all wireless radio, simply switch on Airplane mode.

Tap  → **Settings** → **Network & Internet** → **Airplane mode**. Tap the switch to the **On** status to enable **Airplane** mode.

## 3.6 Using the Bluetooth

BT technology enables wireless communication between devices within a short range, eliminating the need for cable connections. Data transmission is possible even through obstacles such as walls, pockets, and briefcases, as long as the two devices are within range.

### To turn on the BT radio:

Tap  → **Settings** → **Device** → **Bluetooth & other devices**. Tap the **BT** switch to the **On** position.

### To turn off the BT radio:

You can turn off the BT radio the same way you turn it on. If you want to quickly turn off all wireless radio, simply switch on Airplane mode. Tap  → **Settings** → **Network & Internet** → **Airplane mode**. Tap the switch to the **on** status to enable airplane mode.

### Connecting to another BT Device

1. Make sure that the BT function is enabled (as described above).



2. Make sure that the target BT device is turned on, discoverable and within close range. (See the documentation that came with the BT device.)

3. Tap  → **Settings** → **Devices** → **Bluetooth & other devices** → **Add Bluetooth or other device**.

4. Select the device you want to connect from the search results.

5. Depending on the type of BT device that you want to connect to, you will need to enter the pertinent information.

For detailed information on using the BT feature, see Windows' online Help.

## 3.7 Using the Optional barcode Reader

The barcode scanner is an optional feature and powered by Honeywell® modules. Refer to your order specifications for additional information. For additional details, please contact our sales window for more details.

If your model is equipped with the barcode reader module, you can scan barcodes of the following types:

- UPC-A
- code 39
- Code 93
- Code 128
- code 49
- Interleaved 2 of 5
- Matrix 2 of 5
- EAN-13
- Codabar
- PDF417
- Micro PDF417
- QR code
- MaxiCode
- Data Matrix
- Aztec Code
- Postnet

## 3.8 Using the Optional RS232 Module

The LAN Port (RJ45) is an optional feature. Refer to your order specifications for additional



information. To use RS232 port, you can connect a serial device such as a serial mouse or serial communication device.

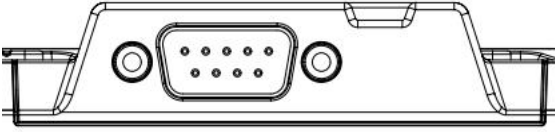



## Section 4 Power Management

### 4.1 AC Adapter

#### CAUTION:

- The AC adapter is specifically intended for use with your Tablet PC. Connecting the AC adapter to any other device can cause damage to the adapter.
- The AC power cord provided with your Tablet PC is intended for use in the country where you made the purchase. If you intend to travel abroad with the Tablet PC, please consult your dealer regarding the suitable power cord for that specific location.
- To disconnect the AC adapter, begin by unplugging it from the electrical outlet and then from the Tablet PC. Performing the procedure in reverse order may result in damage to either the AC adapter or the Tablet PC.
- When disconnecting the connector, always hold the plug head and avoid pulling on the cord.

The AC adapter functions as a converter, converting AC (Alternating Current) power from the electrical outlet to DC (Direct Current) power required by your Tablet PC. Additionally, it charges the battery pack when connected to AC power.

The adapter is compatible with voltage inputs ranging from 100 to 240V AC.

### 4.2 Battery PACK

#### NOTE:

- Charging will not initiate if the battery's temperature falls outside the permitted range of 0°C (32°F) to 45°C (113°F). Once the battery reaches the appropriate temperature, charging will automatically resume.
- While charging, refrain from disconnecting the AC adapter until the battery has reached full charge to avoid prematurely charging the battery.
- The battery features a temperature protection mechanism that restricts the maximum charging capacity to 80% of its total capacity in high temperature conditions. Under such circumstances, the battery will be considered fully charged at 80% capacity.
- The battery level may gradually decrease due to the self-discharge process, even when the battery pack is fully charged. This occurs regardless of whether the battery pack is installed in the Tablet PC.

To charge the battery pack, connect the AC adapter to both the Tablet PC and an electrical outlet. The Battery Indicator  on the Tablet PC will glow amber to indicate that charging is in progress. It is advised to keep the Tablet PC powered off during the charging process. Once the battery is fully charged, the Battery Charge Indicator will glow green.







When the power is off, it takes approximately 4 hours to fully charge both battery packs. If the power is on, it may take around 7.5 hours which is test by the standard JIETA2.0 (charging time may be longer at lower temperatures).

**CAUTION:**

After the Tablet PC has reached full charge, avoid immediately disconnecting and reconnecting the AC adapter for charging. This action may cause damage to the battery.

## 4.2.1 Battery Low Signal and Actions

Battery Icon	Battery Level	Description
	Discharging	The icon shows the charge remaining in 10-percent increments until the charge reaches the low-battery level.
	Low	The battery charge has reached the low battery level.
	Critically low	The battery charge has reached the critical battery level. By default, Windows will display a notification and put your Tablet PC into Hibernation.

The battery icon changes appearance to display the current state of the battery.

When the battery is low, the Tablet PC's Battery Charge Indicator (  ) also blinks red to alert you to take actions.

Always respond to low-battery by connecting the AC adapter, placing your Tablet PC in Hibernation mode, or turning off the Tablet PC.

## 4.2.2 Replacing the Battery Pack

**NOTE:**

Before installing the battery, plug off all cords connected the tablet and turn off the tablet, back facing up.

**This is how you remove the battery.**

1. Slide six battery cover latches to the unlock position, and lift the battery cover out using the opening on the side.
2. Slide the battery latch to the unlock position. Lift the battery out of the battery compartment.

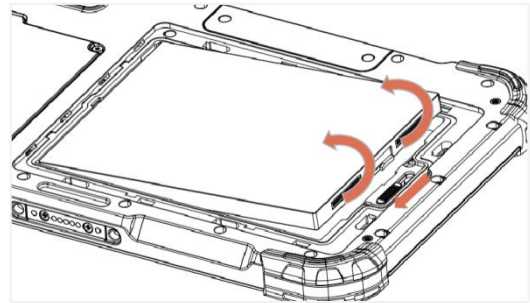
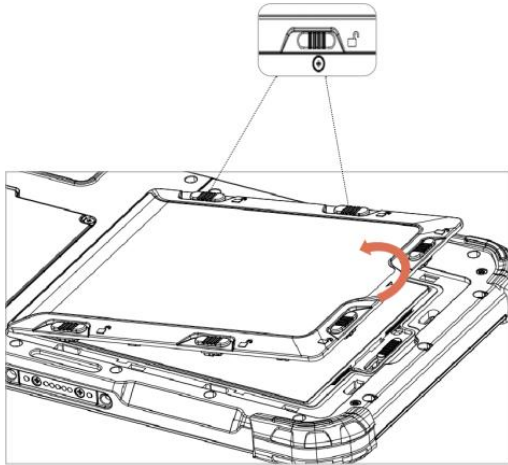

**This is how you install the battery.**

**NOTE:**

Remove the battery cover, and make sure the battery latch is in the unlock position.

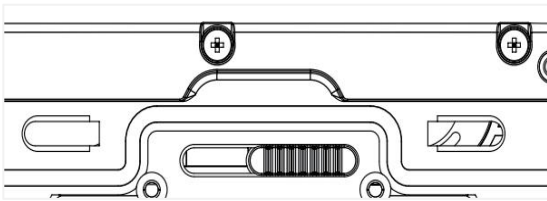

The battery latch is in unlock position.

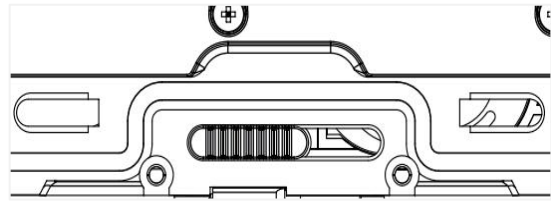

The battery latch is in lock position.

1. Insert the battery at an angle into the battery compartment, and press down until the battery is flat against the housing.
2. Slide the battery latch to the lock position.

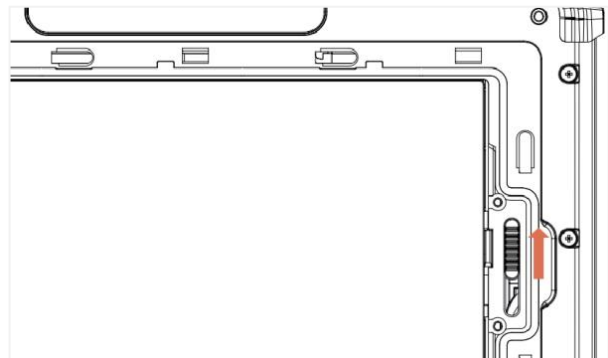
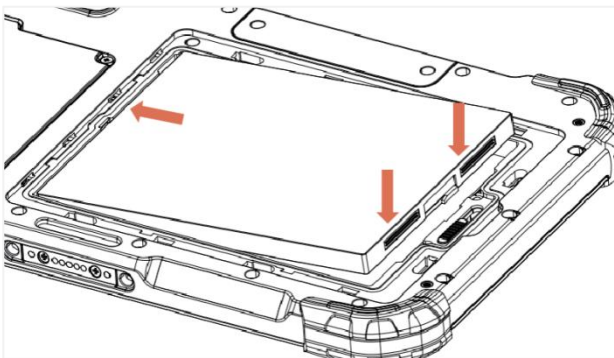

3. Align and insert the battery cover into the battery compartment.
4. Press down the four sides of the battery cover, and slide the six cover latches to the lock position.

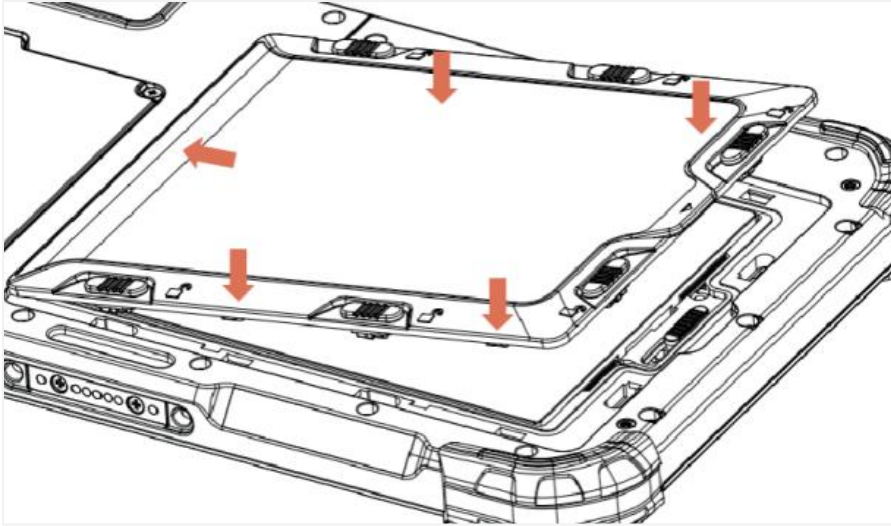

## 4.3 Power Saving Tips

Aside from enabling your Tablet PC's power saving mode, you can do your part to maximize the battery's operating time by following these suggestions.

- Adjust the LCD brightness to the lowest level that is comfortable for you.
- Reduce the time duration before Windows automatically turns off the display.
- If you are not utilizing the wireless module (such as WLAN, BT, or WWAN), deactivate the wireless radio.
- Set a shorter duration for when your tablet sleeps.
- Power off the Tablet PC when it is not in use.



## Section 5 Expanding the Device

### 5.1 Installing WWAN Module

WWAN module is an optional feature, and it is available and tailored for specific models.

**CAUTION:**

Before installing WWAN module, turn off the tablet, back facing up.

This is how you install WWAN Module.

1. Use T6 screwdriver to remove four screws and the compartment cover.
2. Unfasten the screw at the circle location, then insert the module all the way and push it down

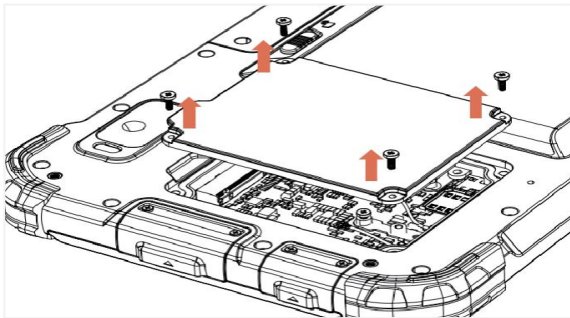

Compartment Cover Screw: M2x5, 4pcs.

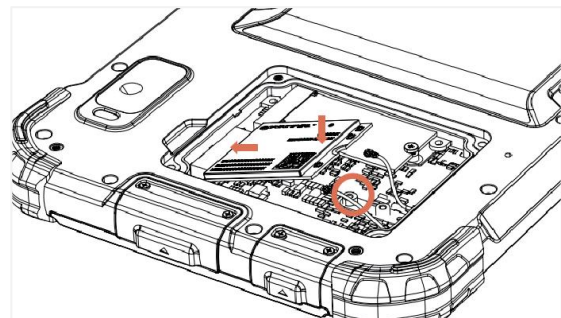

4G LTE Module Screw: M2X3.5, 1pcs.

3. Fasten the screw. peel off the tapes on the cables, and connect the two RF cables to the module.
4. Close the compartment cover and fasten four screws.

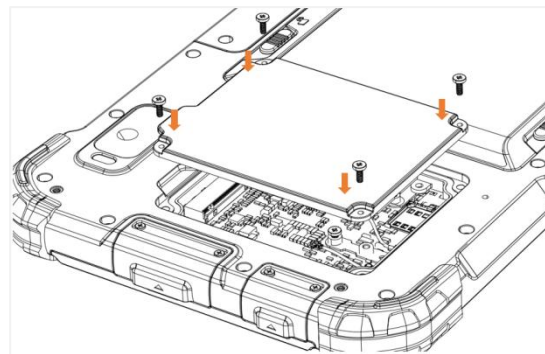



## 5.2 Replacing the SSD Module

**CAUTION:**

Before installing WWAN module, turn off the tablet, back facing up.

1. Use T6 screwdriver to remove four screws and the compartment cover.
2. Unfasten the screw and detach the SSD from the main board.

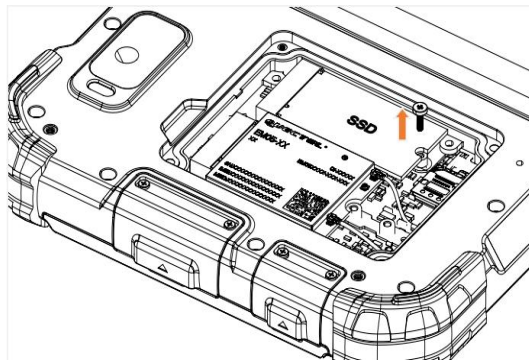
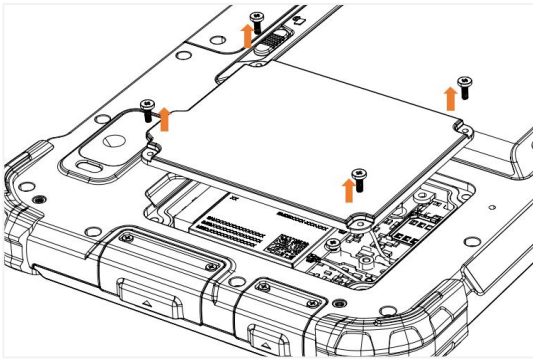

3. Insert the new SSD into place and push it down.
4. Fasten the SSD with screw.

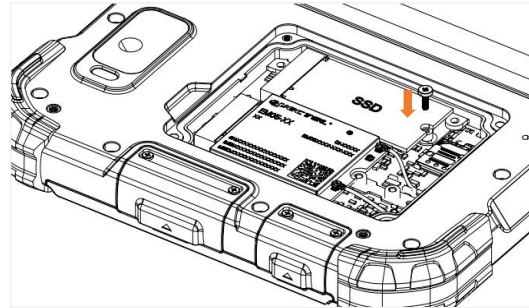
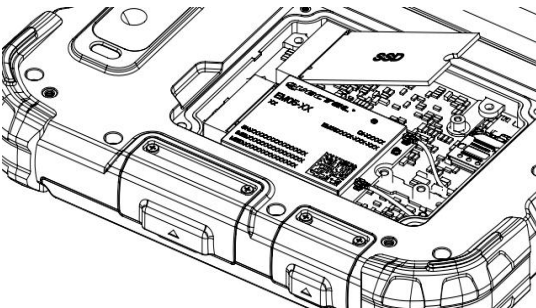

5. Close the compartment cover and fasten four screws.

## 5.3 Docking Connector Pin Definition

R80 supports one 7-pin docking connector at the bottom side. The pin definition is listed as below.

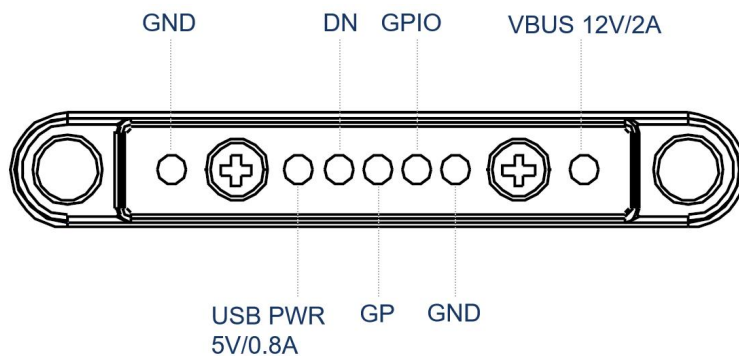



## Section 6 Troubleshooting

Computer issues can stem from hardware, software, or a combination of both. Whenever you encounter a problem, it is likely a common issue that can be easily resolved. In this section, we will guide you on the necessary steps to take when troubleshooting typical computer problems.

To assist you further, here are some helpful tips to follow when faced with any problem:

- Firstly, attempt to identify the specific component of the Tablet PC that may be causing the problem.
- Prior to turning on the Tablet PC, ensure that all peripheral devices are properly powered on.
- If there is an issue with an external device, verify that the cable connections are secure and correctly aligned.
- Confirm that all device drivers are accurately installed.
- Take note of any observations you make. Are there any error messages displayed on the screen? Do any indicators light up? Are there any audible beeps? Providing detailed descriptions will be beneficial when seeking assistance from service personnel.

If any problem persists after you follow the instructions in this section, contact an authorized dealer for help.

### **The removable battery is not charging.**

- Make sure the AC adapter is properly connected, and that the removable battery is properly installed.

### **Nothing appears on the screen.**

- The tablet may be in sleep mode. Press the power button to wake up the display.
- The brightness level may be too low. Increase the brightness.

### **The screen suddenly turns blank and the power indicator goes off.**

- Make sure the AC adapter is properly plugged in.
- If running on battery power, the battery may be drained, charge the battery.

### **Wireless LAN signal quality is poor.**

- The tablet may be out of range. Move the tablet closer to the access point or another wireless LAN device associated with it.
- Verify if there are any interferences in your immediate vicinity, like microwave ovens or cordless phones. Relocate the tablet computer away from objects that may cause interference.

### **I cannot connect to another wireless LAN device.**



- Make sure that wireless LAN feature is powered on.
- Make sure that the SSID setting is the same for every wireless LAN device in the network.
- Your Tablet PC is not recognizing changes. Restart the tablet computer.
- Make sure the IP address or subnet mask setting is correct.

### **I cannot connect to another device with Bluetooth.**

- Make sure that both devices have Bluetooth powered on (For the Tablet , check windows setting to see if Bluetooth is powered on).
- Make sure that the distance between the two devices is within 10 meters and there are no walls or large obstructions between the devices.
- Make sure the both devices are powered on and configured to be discoverable.
- Make sure that both devices are compatible.

### **The GPS application cannot find my location.**

- Make sure that GPS is turned on.
- Make sure that GPS receiver and the location sensor are enabled in Setting.
- The tablet computer may be out of coverage area. Move your tablet computer outdoors or closer to a window.
- Check if your surroundings have interferences, such as microwave ovens, cordless phones. Move the tablet computer away from objects causing interference.

### **No sound is produced.**

- Adjust volume of the tablet computer by pressing on the volume rocker.
- If using an external audio device, make sure that the cable is properly connected.

### **I cannot project the tablet computer display to another monitor.**

- Make sure the VGA driver is installed.
- Make sure the output setting selected is correct.

### **Battery leaking or swollen.**

- The lithium battery used in this tablet may swell after being charged/ discharged many times, but there is no problem regarding safety.
- Continued use in such a state may result in the battery getting jammed, so please stop using the battery, and purchase a new one.

### **Copyright Notice**

This document may not be reproduced, duplicated, translated, or transmitted in any form or by any electronic or mechanical means without the prior written consent of the original manufacturer.

### **Trademark Notice**

Brand and product names are protected by trademarks or registered trademarks owned by their respective owners.